

DN65 TO DN80 MAINLINE ONLY

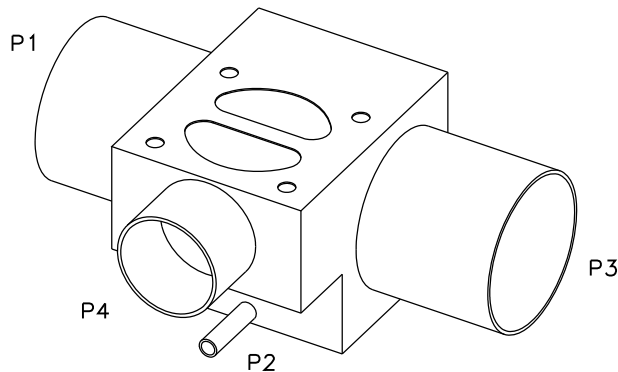

DN100 MAINLINE ONLY

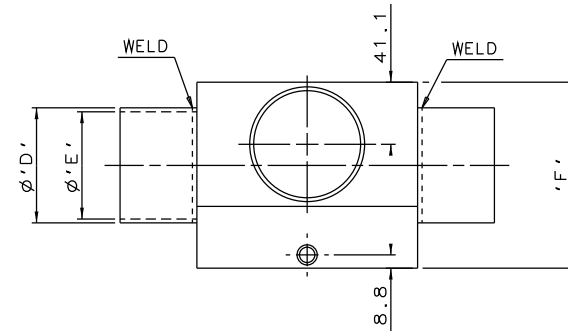
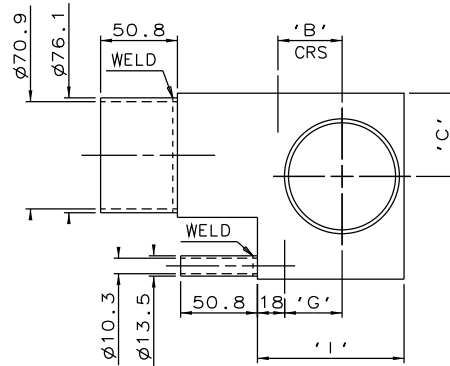
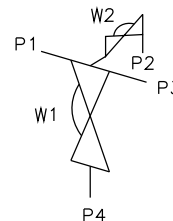
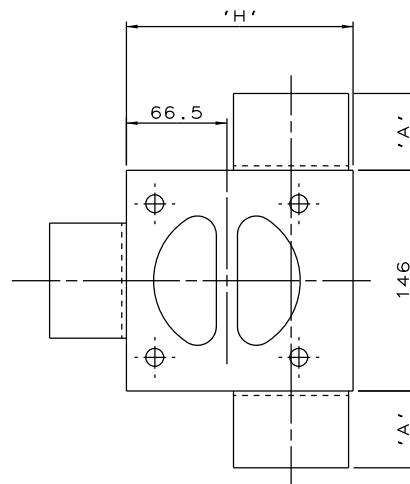

ORIENTATION AS PER P&ID DIAGRAM FOR OPTIMUM DRAINABILITY.

MAINLINE SIZE	A	B	C	ϕD	ϕE	F	G	H	I	BODY WEIGHT
mm	mm	mm	mm	mm	mm	mm	mm	mm	mm	Kgs
DN65	50.8	42.5	55.0	76.1	70.9	123.0	38.0	150.0	97.0	11.9
DN80	50.8	48.9	61.0	88.9	83.7	123.0	44.4	163.0	110.0	12.0
DN100	101.6	61.6	73.0	114.3	109.1	146.0	57.1	189.0	136.0	15.6

The information on this sheet is Private and Confidential and is the property of Crane Process Flow Technologies Limited and must not be published directly or indirectly in any manner whatsoever without the written permission of the Company and must not be used in any way detrimental to their interests.
© Crane Process Flow Technologies

CRANE Process Flow Technologies
A Crane Co. Company

Saunders
The Science Inside

Title
SCHEDULE OF LEADING DIMENSIONS FOR DN65
WEIR 'T' BODY WITH DN8 BACK SAMPLE
ALL ENDS BUTT WELD ISO 1127 S1 TUBING

Drawn RI Date 25.05.12

Checked JRD Date 25.05.12

First Angle Projection Method E

DO NOT SCALE

UNCONTROLLED IN HARD COPY FORMAT

Drawing No. WEB-221 Issue. 1

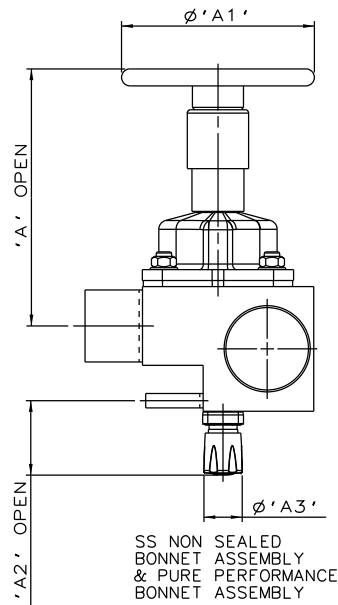

SS NON SEALED
BONNET ASSEMBLY
& PURE PERFORMANCE
BONNET ASSEMBLY

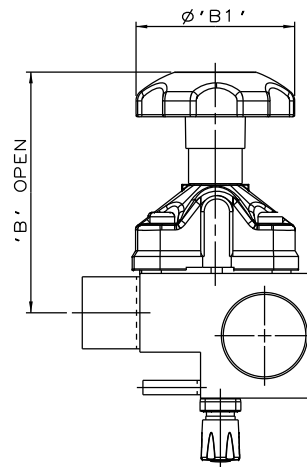

PES BONNET
& PURE PERFORMANCE
BONNET ASSEMBLY

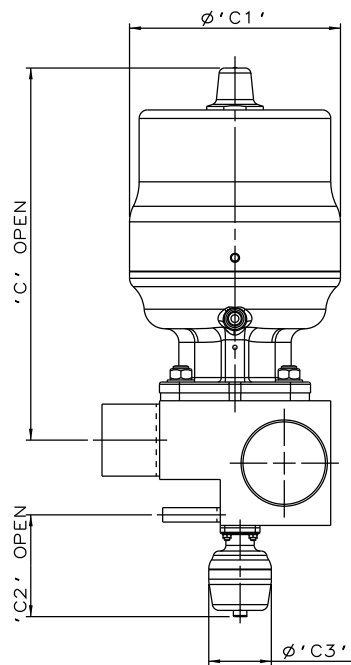

*S360 ACTUATORS

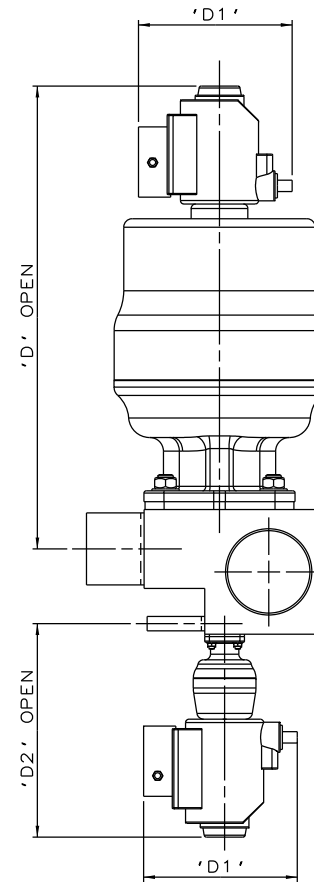

*S360 ACTUATORS
WITH I-VUE SENSOR

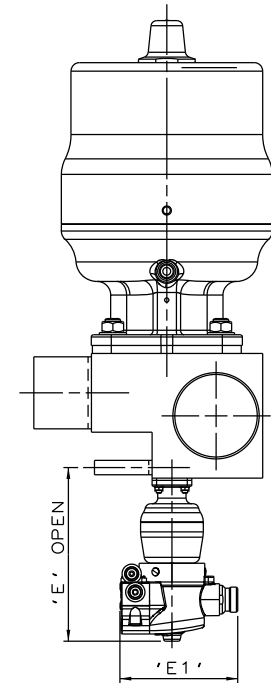

*S360 ACTUATORS
WITH M-VUE SENSOR

BLOCK CAN BE FITTED WITH ANY EXISTING
SUITABLE TOP WORK COMBINATIONS

*DIMENSIONS SHOW MAXIMUM ENVELOPE FOR ALL MODES

BRANCH/SAMPLE SIZE		A		A1		A2		A3		B		B1		C		C1		C2		C3		D		D1		D2		E		E1	
mm	inch	mm	inch	mm	inch	mm	inch	mm	inch	mm	inch	mm	inch	mm	inch	mm	inch	mm	inch	mm	inch	mm	inch	mm	inch	mm	inch	mm	inch	mm	inch
DN40xDN15	1.5x0.5	234.1	9.22	170.0	6.69	65.2	2.57	34.0	1.34	227.1	8.94	140.0	5.51	335.1	13.19	186.0	7.32	88.8	3.50	55.0	2.18	415.1	16.34	136.0	5.33	187.8	7.39	153.8	6.06	103.8	4.09

The information on this sheet is Private and Confidential and is the property of Crane Process Flow Technologies Limited and must not be published directly or indirectly in any manner whatsoever without the written permission of the Company and must not be used in any way detrimental to their interests.
© Crane Process Flow Technologies

CRANE Process Flow Technologies
A Crane Co. Company

Saunders
The Science Inside

Title
SCHEDULE OF LEADING DIMENSIONS FOR DN65/2.50
WEIR 'T' BODY WITH DN8/0.25 BACK SAMPLE
ALL ENDS BUTT WELD ISO 1127 S1 TUBING
FITTED WITH TOPWORKS OPTIONS

Drawn R1 Date 09.05.17 UNCONTROLLED IN
Checked RND Date 09.05.17 HARD COPY FORMAT

First Angle Projection Method E DO NOT SCALE Drawing No. WEB-221-ASSY Issue. 1